

TECHNICAL DATA

B SERIES



ARNETT
ENGINEERED SOLUTIONS

ARNETT ENGINEERED SOLUTIONS
61 INNOVATION DRIVE, BAMBERG, SC 29003

(844) 785-7585 | SALES@ARNETT.COM

WWW.ARNETT.COM

BIDIRECTIONAL KNIFE GATE VALVE, WAFER DESIGN

DESCRIPTION

Wafer style, bidirectional knife gate valve. Cast body, composed by two bolted parts, with inside sliding guides to provide a smooth operation. High flow rates with low pressure drops. Several seat and packing materials available. Face to face dimension according **CMO Valves** standard.

GENERAL APPLICATIONS

This knife gate valve is appropriate for liquids with a solids concentration of maximum 8%.

Designed for a wide range of applications such as:

- Pulp and Paper.
- Mining.
- Effluent handling plants.
- Chemical plants.
- Food and beverage.
- Bulk conveying.
- Sewage applications.
- Chemical plants.

SIZES

DN50 to DN600

* Others **ND** on request.

FLANGE CONNECTION DRILLINGS

The standard flange connection is according to **PN10**. Other flange connections such as, **ANSI 150, PN6 – PN16 – PN25, British Standard, Australian Standard, JIS Standard**, are available under request.

The pressures indicated in the table can be used in both directions of the valve.

WORKING PRESSURE (ΔP)

DN50 - DN250	10 bar
DN300 - DN400	6 bar
DN450	5 bar
DN500 - DN600	4 bar
DN700 - DN1000	3 bar

* Other pressures, consult.



Fig. 1

APPLICATION OF EUROPEAN DIRECTIVES

See document of European Directives applicable to **CMO Valves**.

* For category and zone information, contact technical-commercial department at **CMO Valves**.

QUALITY DOSSIER

All valves are tested hydrostatically at **CMO Valves** and material and test certificates can be provided.

- Body test = working pressure x 1.5
- Seat test = working pressure x 1.1

B SERIES

As part of a process of on-going product and service development, **CMO Valves** reserves the right to amend and change the data and content of this document at its discretion at any time without notice. The publication of the latest revision renders all previous documents invalid.

Installation and Maintenance Manual available at www.cmovalves.com.

ADVANTAGES

The main characteristic of this knife gate valve is that it has full and continuous bore. This means that in open position it has no cavity, therefore there are no turbulences in the fluid. The **type B** is constructed with two body half design. The inside surface of the two bodies is machined and they are assembled with bolts creating a solid block. The valve gate slides inside of the two body parts thanks to several PE-UHMW nylon sliding guides installed inside of the bodies. In addition, the body has a manhole cover at the bottom to facilitate valve cleaning.

The stem protection hood is independent from the hand wheel fixing system, so the hood can be removed without removing the hand wheel. This point allows normal maintenance operations like greasing of the spindle, etc. The spindle (stem) of the **CMO Valves** is made of stainless steel AISI304. This point is very important because there are manufacturers that manufacture it with 13% CR and it gets rusty in a very short time.

The hand wheel of the manual actuator is made of nodular iron. Some manufacturers manufacture it on normal cast iron and they can break easily when receiving any big torque or knock. The bridge of the **CMO Valves** manual actuator is manufactured in a compact way, with the bronze nut protected in a greased and closed box. This point gives the possibility to move it with a key even without the hand wheel (in other manufacturer valves this is not possible).

The pneumatic actuator upper and lower caps are made of nodular iron GJS400, therefore their resistance to the knocks is very high. This characteristic is essential in this type of pneumatic cylinder.

The sealing o-rings of the pneumatic cylinders are commercial and they can be bought all over the world, it is not needed, therefore, to contact **CMO Valves** every time a seal is required.

STANDARD COMPONENTS LIST

COMPONENT	NODULAR IRON	ST. STEEL
1 BODY	GJS500-7	CF8M
2 GATE	AISI304	AISI316
3 BODY SEAL	CARDBOARD	
4 PACKING GLAND	GJS500-7	CF8M
5 PACKING	SYNT. + PTFE	
6 SEAL	EPDM	
7 SUPPORT PLATES	S275JR	
8 RING	AISI316	
9 SEAT	EPDM	
10 JOINT	EPDM	
11 CAP	S275JR	AISI316
12 SPINDLE	AISI304	
13 BRIDGE	GJS500-7	
14 STEM NUT	BRONZE	
15 CHECK NUT	STELL	
16 HANDWHEEL	GJS500-7	
17 NUT	5.6 ZINC	
18 HOOD	STELL	
19 TOP CAP	PLASTIC	

Table. 1

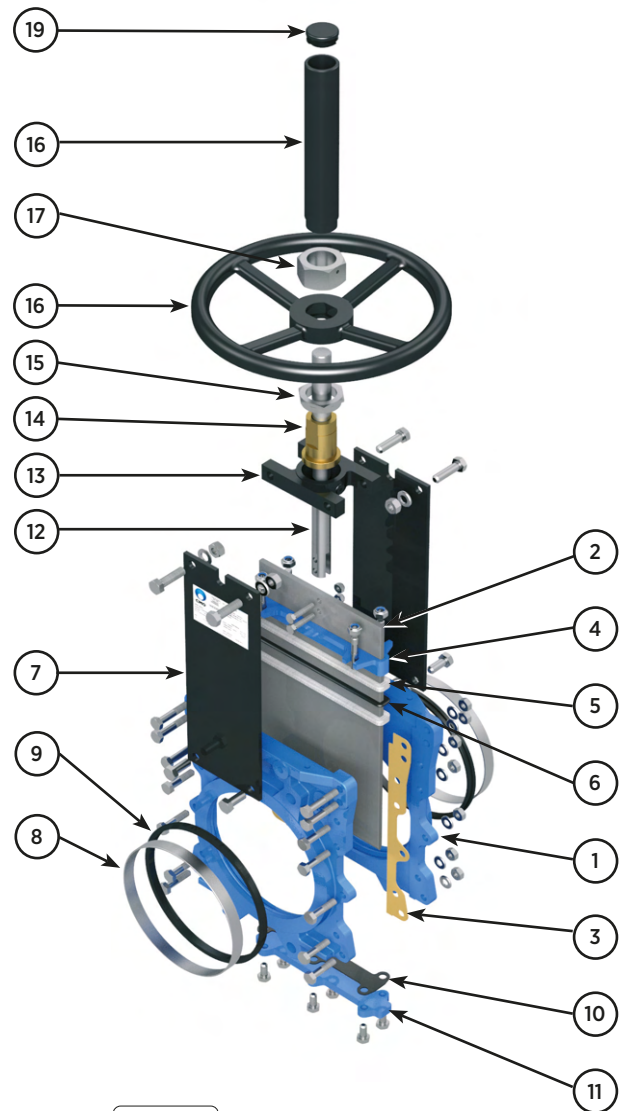

Fig. 2

Note: The stainless steel valves have slides on each side of the body to avoid friction and possible seizure of the valve, these slides are made of PE-UHMW.

DESIGN CHARACTERISTICS

1. BODY

Cast iron body with reinforcements, made up of two bolted parts and with a wafer design. The stainless steel version has internal PE-UHMW guides that provide smooth sliding of the knife gate, whereas the GJS500-7 versions do not need guides. The inner surface of both parts is fully machined and is joined using bolts to create thereby a solid block. Designed with full bore and due to the shape of the interior of the body, it means that in the open position it does not produce cavitation, and therefore, there is no turbulence in the fluid, with minimal pressure loss, providing high flow rates.

In the lower part of the body, this type of valve has a man-hole cover to facilitate the cleaning of accumulated deposits. The cover is attached to the body by bolts and has a rubber gasket to prevent leaks to the outside.

The standard manufacturing materials are GJS500-7 nodular cast iron and CF8M stainless steel. Other materials such as A216WCB carbon steel and stainless steel alloys (AISI316Ti, Duplex, 254SMO, Uranus B6, etc.) are available upon request. As standard, cast iron or carbon steel valves are painted with an anti-corrosive EPOXY protection (colour RAL 5015). Other types of anti-corrosive protections are available on request.

2. GATE

The standard manufacturing materials are AISI304 stainless steel in valves with iron body and AISI316 stainless steel in valves with CF8M body. In both cases, when the high pressures to be supported require it, we also use DUPLEX material. Other materials or combinations can be supplied on request.

The gate is polished on both sides to provide a smooth contact surface with the resilient seat. At the same time, the gate is rounded to prevent the seat from being cut. Different degrees of polishing, antiabrasion treatments and modifications are available to adapt the valves to the customer's requirements.

3. SEAT

Six types of seats are available according to the working application:

SEAT 1

Metal / metal seat.

This type of seat does not include any kind of resilient seat and the estimated leakage (considering water as the test fluid) is 1.5% of the pipe flow.

SEAT 2

Standard soft-seated valve

This seat construction includes a resilient joint that is held on the valve body by an AISI316 stainless steel retaining ring. Considering that the valve is bidirectional it has two joints.

SEAT 3

Soft-seated valve with reinforced socket.

This seat construction includes a resilient joint that is held on the valve body by a reinforced socket with two functions (protect the valve body from abrasion and clean the gate when the valve is working with particles that stick on the gate). Considering that the valve is bidirectional it has two joints and two reinforced sockets.

SEAT 4 / 5 / 6

The same as seats 1, 2 and 3 but including a deflector.

The deflector is a conical shaped ring located on the valve inlet with two functions (protect the valve body from abrasion guide the flow to the centre of the valve). There are three materials available for the reinforced ring and deflector (CA-15, CF8M and Ni-hard steel).

Nota: En algunas aplicaciones otros tipos de gomas son utilizadas, tales como hipalón, butilo o caucho natural. Por favor contacto con nosotros en caso de que tengan tal requerimiento.

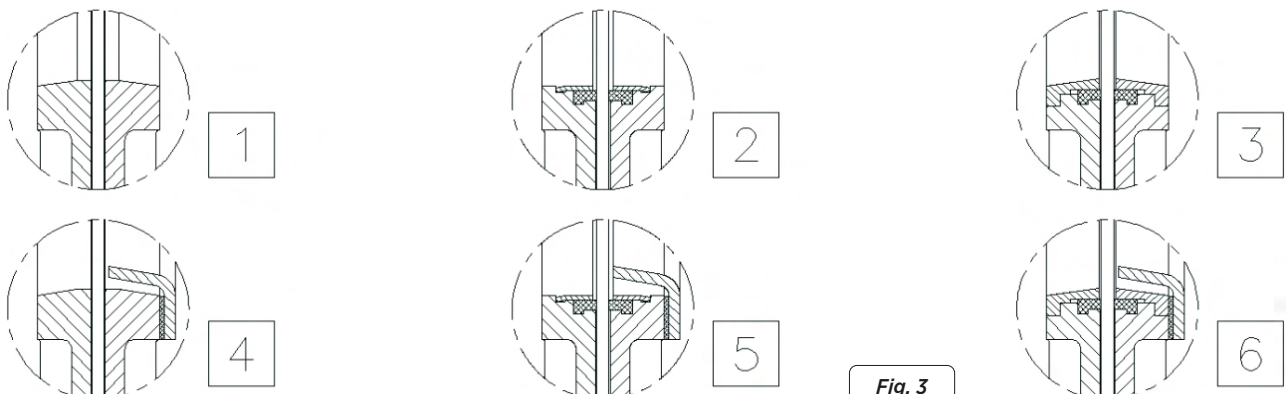

Fig. 3

RESILIENT SEAT MATERIALS

EPDM

This is the standard resilient seat fitted on **CMO valves**. It can be used in many applications, however, it is generally used for water and products diluted in water at temperatures no higher than 90°C*. It can also be used with abrasive products and it provides the valve with 100% watertight integrity.

FKM

Suitable for corrosive applications and continuous high temperatures of up to 190°C and peaks of 210°C. It provides the valve with 100% watertight integrity.

NITRILE

It is used in fluids containing fats or oils at temperatures no higher than 90°C*. It provides the valve with 100% watertight integrity.

SILICONE

Mainly used in the food industry and for pharmaceutical products with temperatures no higher than 200°C. It provides the valve with 100% watertight integrity.

PTFE

Suitable for corrosive applications and pH between 2 and 12. Does not provide the valve with 100% watertight integrity. Estimated leakage: 0.5% of the tube flow.

4. PACKING

CMO Valves's standard packing is composed of three lines with a specially designed EPDM O-ring in the middle which provides watertight integrity between the body and the gate, preventing any type of leakage to the atmosphere. It is located in an easily accessible place and can be replaced without dismantling the valve from the pipeline. Below we indicate various types of packing available according to the application in which the valve is located:

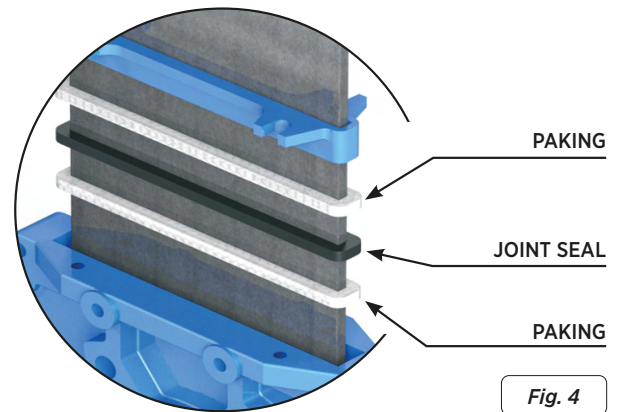

Fig. 4

1. SYNTHETIC + PTFE

This packing is composed of braided synthetic fibres soaked in PTFE both inside and out. It is for general use in hydraulic applications in both pumps and valves and in all types of fluids, especially corrosive ones, including concentrated and oxidising oils. It is also used in liquids with solid particles in suspension.

2. GREASED COTTON (Recommended for hydraulic services)

This packing is composed of braided cotton fibres soaked in grease both inside and out. It is for general use in hydraulic applications in both pumps and valves.

3. DRY COTTON

This packing is composed of cotton fibres. It is for general use in hydraulic applications with solids.

4. COTTON + PTFE

This packing is composed of braided cotton fibres soaked in PTFE both inside and out. It is for general use in hydraulic applications in both pumps and valves.

5. GRAPHITE

This packing is composed of high-purity graphite fibres. A diagonal braiding system is used and it's impregnated with graphite and lubricant which helps to reduce porosity and improve operation.

It has a wide range of applications as graphite is resistant to steam, water, oils, solvents, alkali and most acids.

6. CERAMIC FIBRE

This packing is composed of ceramic material fibres. Its main applications are with air or gas at high temperatures and low pressures.

SEAT/SEALS			PACKING			
MATERIAL	T ³ MÁX (°C)	APLICACIONES	MATERIAL	P (bar)	T ³ MÁX (°C)	pH
EPDM (E)	90° *	Water, mineral acids and oils	Greased cotton	10	100°	6-8
Nitrile (N)	90° *	Hydrocarbons, oils and greases	Dry cotton (AS)	0,5	100°	6-8
FKM (V)	200°	Hydrocarbons and solvents	Synthetic + PTFE	100	-200°+270°	0-14
Silicone (S)	200°	Food Products	Graphite	40	650°	0-14
* EPDM and Nitrile: possible up to Max. Temperature: 120°C on request.			Ceramic Fibre	0,3	1400°	0-14

Nota: More details and other materials on request

Table. 2



5. STEM

The stem on the **CMO Valves** is made of AISI 304 stainless steel. This characteristic provides high resistance and excellent corrosion-resistant properties.

The valve design can be rising stem or non-rising stem. When rising stem is required a stem hood is supplied to protect the stem from contact with dust and dirt, as well as keeping it lubricated

6. PACKING GLAND

The packing gland allows uniform force and pressure to be applied to the packing to ensure watertight integrity. As standard, valves with cast iron body include GJS450 packing glands, whilst valves with stainless steel body have CF8M packing glands.

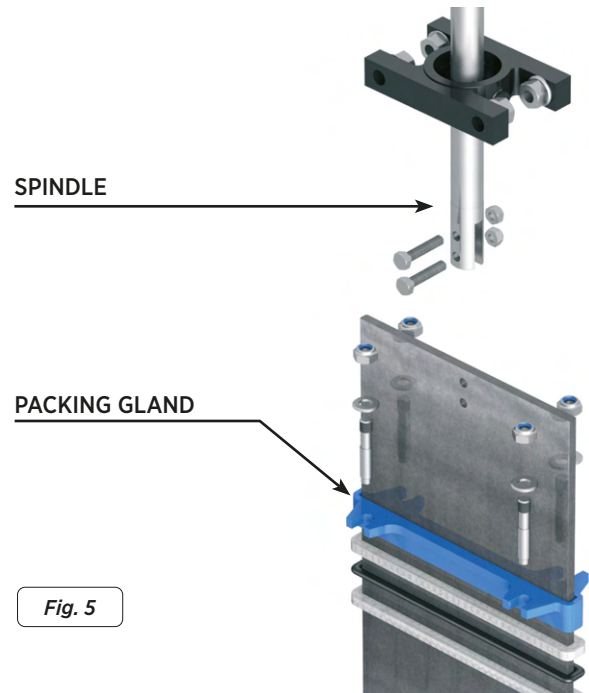

Fig. 5

7. ACTUATORS

All types of actuators can be supplied, with the advantage that thanks to the **CMO Valves** design they are fully interchangeable. This design allows the customer to change the actuators themselves and no extra assembly accessories are required. On the other hand, and if necessary, **CMO Valves** supplies it.

The chainwheel, gearbox actuators are also available with non-rising stems. Pneumatic drives can be single or double acting, single acting drives in turn can be spring opening or closing.

Manual Drives
Handwheel (*)
Chain handwheel (*)
Lever
Geared motor (*)
Others (square stem)

Availability of Accessories
Mechanical stoppers
Locking devices
Emergency manual drives
Electrovalves
Positioners
Limit switches
Proximity detectors
Straight floor stand (Fig. 6)
Leaning floor stand (Fig. 7)

Automatic Drives
Electric actuator (*)
D/E & S/E pneumatic cylinder
Hydraulic cylinder

(*) Available in rising and non-rising stem versions.

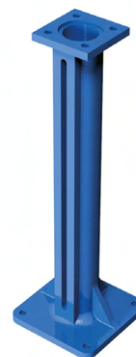

Fig. 6

LEANING FLOOR STANDS.



Fig. 7

STRAIGHT FLOOR STANDS.

Stem extensions have also been developed, allowing the drive to be located far away from the valve, to suit all needs. Please ask our engineers beforehand.

H/A = RISING STEM
H/NA = NON-RISING STEM

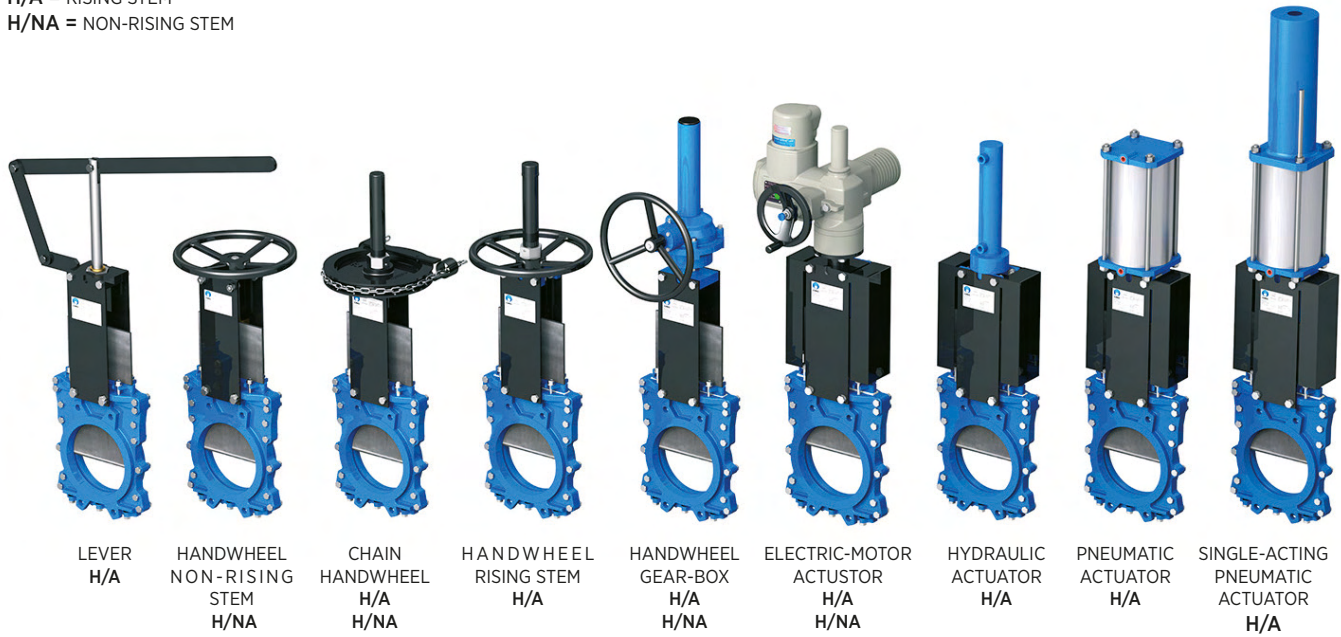

Fig. 8

ACCESSORIES AND OPTIONS

Different types of accessories are available to adapt the valve to specific working conditions such as:

MIRROR POLISHED GATE

The mirror polished gate is especially recommended in the food industry and, as standard, in applications in which solids can stick to the gate. It is an alternative to ensure the solids slide off and do not stick to the gate.

PTFE LINED GATE

As with the mirror polished gate, it improves the valve's resistance to products that can stick to the gate.

STELLITED GATE

Stellite is added to the gate's lower edge to protect it from abrasion.

SCRAPER IN THE PACKING

Its function is to clean the gate during the opening movement and prevent possible damage to the packing.

AIR INJECTION IN THE PACKING GLAND

By injecting air in the packing, an air chamber is created which improves the watertight integrity.

HEATING JACKET

Recommended in applications in which the fluid can harden and solidify inside the valve's body. An external jacket keeps the body temperature constant, preventing the fluid from solidifying.

DRIVE OR YOKE SUPPORT

Made of EPOXY-coated steel (or stainless steel to order), its robust design gives it great rigidity in order to withstand the most adverse operation conditions.

MECHANICAL LIMIT SWITCHES, INDUCTIVE SWITCHES AND POSITIONERS

Limit switches or inductive switches are installed to indicate precise valve position, as well as positioners to indicate continuous position.

SOLENOID VALVES

For air distribution to pneumatic actuators.

CONNECTION BOXES, WIRING AND PNEUMATIC PIPING

Fully assembled units can be supplied with all the necessary accessories.

MECHANICAL STROKE LIMITING STOP (MECHANICAL STOPPERS):

These allow the stroke to be mechanically adjusted, limiting the valve run.

MECHANICAL LOCKING DEVICE:

Allows the valve to be mechanically locked in a fixed position.

EMERGENCY MANUAL ACTUATOR (HAND WHEEL /GEAR BOX)

Allows manual operation of the valve in the event of power or air failure.

FLUSHING HOLES IN BODY

Several holes can be drilled in the body to flush air, steam or other fluids out in order to clean the valve seat before sealing.

TRIANGULAR (V-NOTCH) AND PENTAGONAL DIAPHRAGM WITH INDICATION RULE

Recommended for applications in which flow regulation is required. Allows flow control according to the valve's opening percentage.

INTERCHANGEABLE ACTUATORS

All actuators are easily interchangeable, except the lever

EPOXY COATING

All cast iron and carbon steel bodies and components on **CMO Valves** are EPOXY coated, giving the valves great resistance to corrosion and an excellent finish.

CMO Valves's standard colour is blue, RAL-5015.

GATE SAFETY PROTECTION

In accordance with European Safety Standards ("EC" marking), **CMO Valves** automated valves are equipped with gate guards, to prevent any objects from being accidentally caught in the gate.

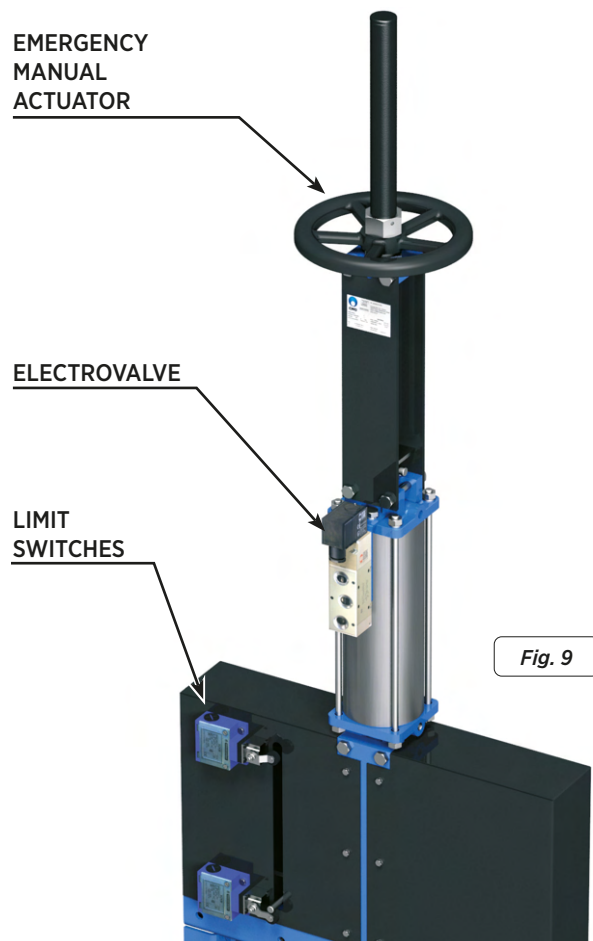

TYPES OF EXTENSION

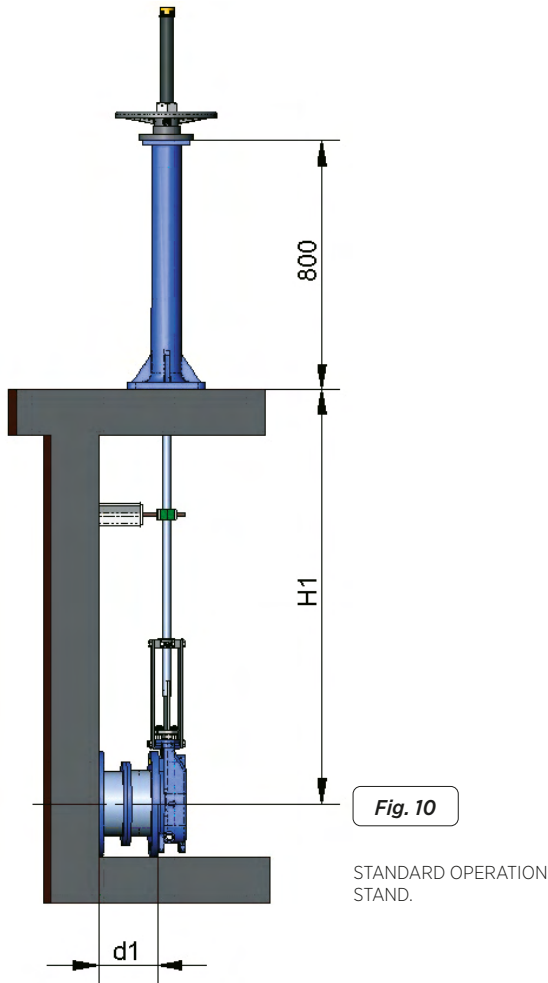

Fig. 10

STANDARD OPERATION STAND.

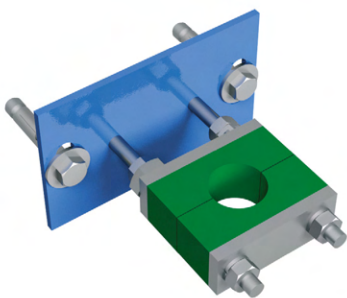

Fig. 11

STEM GUIDE BRACKET

COMPONENT LIST

COMPONENT	STANDARD VERSION
Stem	AISI 304
Rod	AISI 304
Support-Guide	Carbon steel with EPOXY coating
Guide	PA6
Stand	GJS500-7 with EPOXY coating

When the valve needs to be operated from a distance, the following different types of actuators can be fitted:

1- FLOOR STAND

This extension is done by coupling a spindle to the stem. The desired extension is achieved by defining the length of the spindle. A floor stand is normally installed to support the drive.

The definition variables are as follows:

H1 = Distance from valve centre to base of the stand

d1 = Separation from the wall to the end of the connecting flange

CHARACTERISTICS:

- It can be coupled to any type of drive.
- We recommend a stem guide bracket every 1.5 m
- The standard floor stand is 800 mm high.
- Option to use a position indicator to determine the valve's percentage of opening.
- Leaning stand available to order
- Other floor stand measurements available on request.



LEANING STAND.

Fig. 12

2.- PIPE

This consists of raising the drive. The pipe will rotate in the same direction as the wheel when the valve is operated. The valve always remains at the same height.

The definition variables are as follows:

H1 = Distance from valve centre to base of the stand

d1 = Separation from the wall to the end of the connecting flange

CHARACTERISTICS:

- Standard drives: handwheel and top square.
- A pipe guide bracket is recommended every 1.5 m.
- The standard materials are: EPOXY-coated carbon steel and stainless steel.

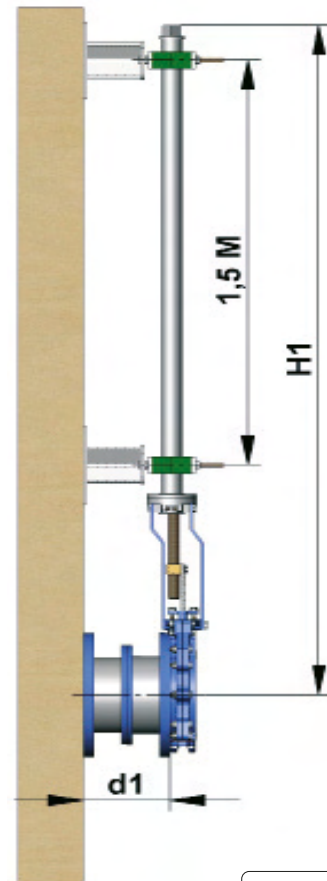
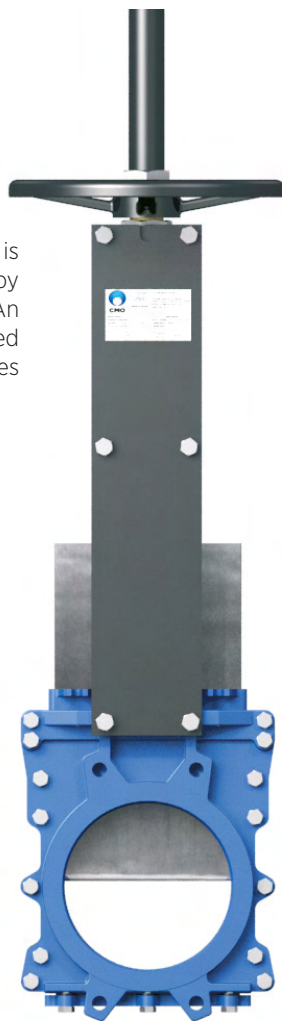

Fig. 13

3.- ELONGATED SUPPORT PLATES

When a short extension is required, it can be achieved by extending the support plates. An intermediate yoke can be fitted to reinforce the support plates structure.

Fig. 14



4.- UNIVERSAL CARDAN JOINT

If the valve and the drive are not in correct alignment, the problem can be resolved by fitting a universal cardan joint.

This option is only valid for non-rising stem drives.

Fig. 15



RISING-STEM HANDWHEEL

Suitable when no size limitations exist.

The definition variables are as follows:

B = Max. width of the valve (without drive).

P = Max. height of the valve (without drive).

OPTIONS:

- Square nut
- Locking devices
- Extensions: elongated plates...
- ND higher than those give in the table
-

ACTUATOR:

- Handwheel
- Stem
- Guide bearings on the yoke.
- Nut

AVAILABLE:

- ND50 to DN600.

* Other ND on request.

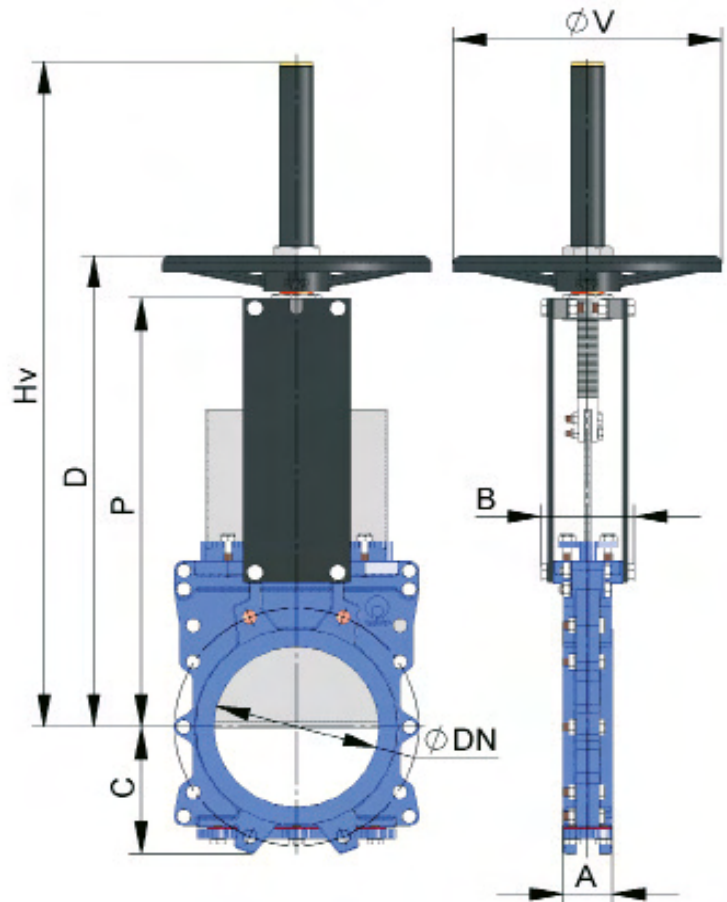

Fig. 16

DN	ΔP(bar)	A	B	C	P	Hv	D	øV
50	10	40	92	63	241	409	280	225
65	10	40	92	70	268	436	307	225
80	10	50	92	92	294	469	333	225
100	10	50	92	105	334	502	373	225
125	10	50	102	120	367	585	406	225
150	10	60	102	130	419	644	458	225
200	10	60	119	160	525	815	578	325
250	10	70	119	198	626	1016	679	325
300	6	70	119	234	726	1116	779	380
350	6	96	290	256	797	1336	906	450
400	6	100	290	292	903	1442	1012	450
450	5	106	290	308	989	1628	1098	450
500	4	110	290	340	1101	1738	1210	450
600	4	110	290	400	1307	2046	1416	450

Table. 5

NON-RISING STEM HANDWHEEL

Suitable when no size limitations exist.

The definition variables are as follows:

B = Max. width of the valve (without drive).

P = Max. height of the valve (without drive).

OPTIONS:

- Square nut
- Locking devices
- Extensions: elongated plates...
- ND higher than those give in the table

ACTUATOR:

- Handwheel
- Stem
- Guide bearings on the yoke.
- Nut

AVAILABLE:

- ND50 to DN600.

* Other ND on request.

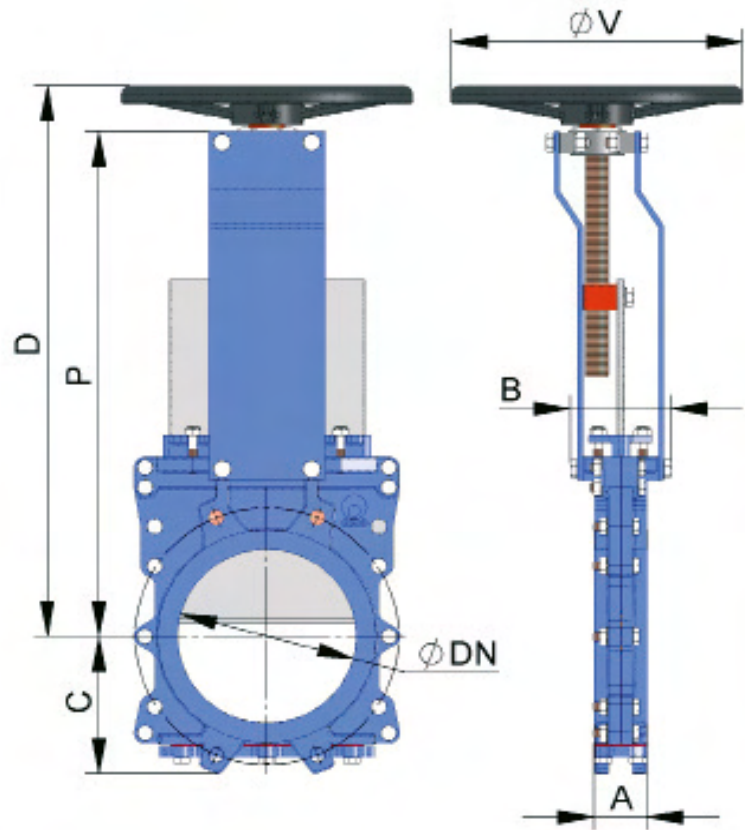

Fig. 17

DN	$\Delta P(\text{bar})$	A	B	C	P	D	ϕV
50	10	40	101	63	241	280	225
65	10	40	101	70	268	308	225
80	10	50	101	92	294	333	225
100	10	50	101	105	334	373	225
125	10	50	111	120	367	407	225
150	10	60	111	130	419	458	225
200	10	60	128	160	525	578	325
250	10	70	128	198	626	679	325
300	6	70	128	234	726	779	380
350	6	96	305	256	797	906	450
400	6	100	305	292	903	1012	450
450	5	106	305	308	989	1098	450
500	4	110	305	340	1101	1210	450
600	4	110	305	400	1307	1416	450

Table. 6

CHAIN HANDWHEEL

Widely used in raised installations with difficult access, the wheel is fitted in vertical position.

The definition variables are as follows:

B = Max. width of the valve (without drive).

D = Max. height of the valve (without drive).

OPTIONS:

- Square nut
- Locking devices
- Extensions: elongated plates...
- ND higher than those give in the table

ACTUATOR:

- Handwheel
- Stem
- Nut
- Hood
- Chain
- Chain

AVAILABLE:

- ND50 to DN600.
- From ND600 the actuator is with gears.

* Other ND on request.

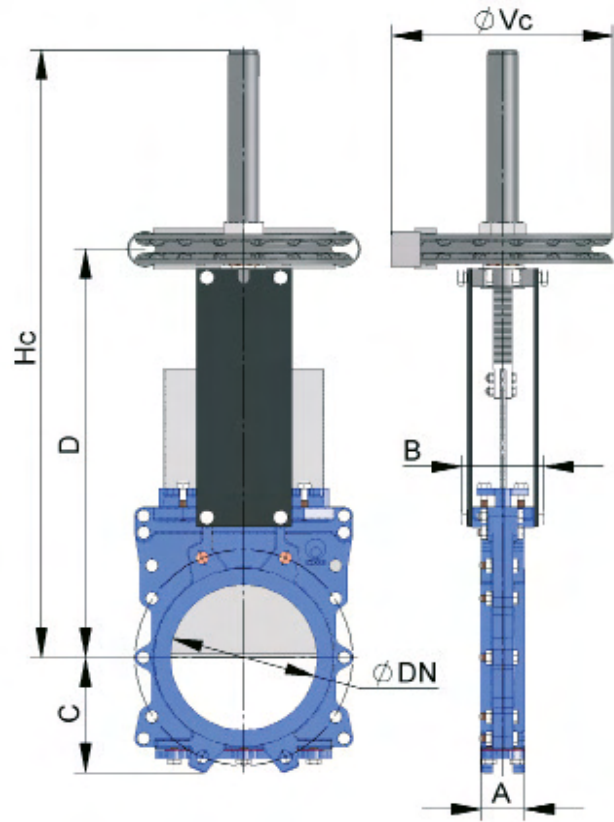

Fig. 18

DN	ΔP bar	A	B	C	D	Hc	øVc
50	10	40	92	63	264	409	225
65	10	40	92	70	291	436	225
80	10	50	92	92	317	469	225
100	10	50	92	105	357	502	225
125	10	50	102	120	390	585	225
150	10	60	102	130	442	644	225
200	10	60	119	160	551	815	300
250	10	70	119	198	652	1016	300
300	6	70	119	234	752	1116	300
350	6	96	290	256	879	1336	402
400	6	100	290	292	985	1442	402
450	5	106	290	308	1071	1628	402
500	4	110	290	340	1183	1738	402
600	4	110	290	400	1389	2046	402

Table. 7

LEVER

The definition variables are as follows:

B = Max. width of the valve (without drive).

D = Max. height of the valve (without drive).

ACTUATOR:

- Lever
- Rod
- Guide bearing
- External limiting switches to maintain the position

AVAILABLE:

- ND50 to DN300.

* Other ND on request.

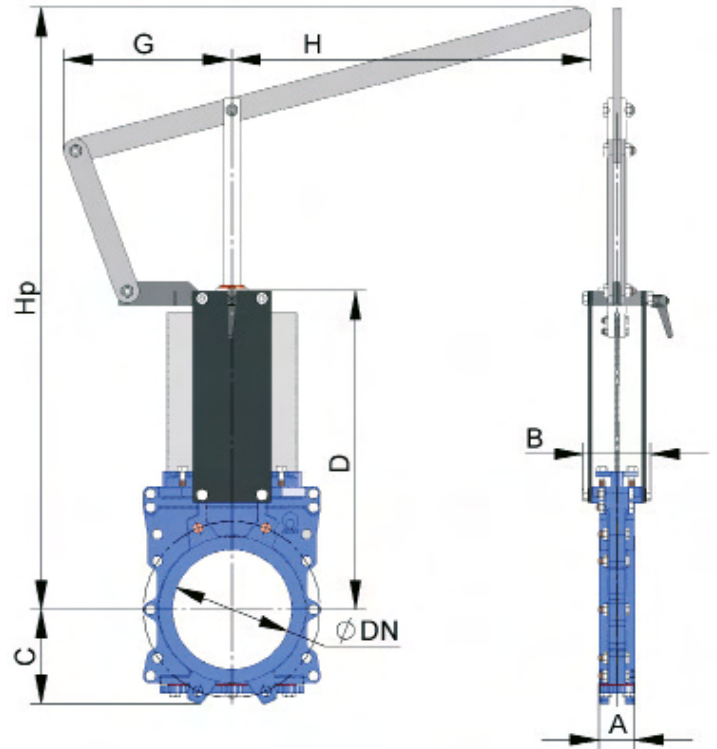

Fig. 19

DN	ΔP bar	A	B	C	D	P	G	H	Hp
50	10	40	92	63	264	155	325	504	1/4"
65	10	40	92	70	291	155	325	526	1/4"
80	10	50	92	92	317	155	325	549	1/4"
100	10	50	92	105	357	155	325	605	1/4"
125	10	50	102	120	390	155	425	902	3/8"
150	10	60	102	130	442	155	425	956	3/8"
200	10	60	119	160	551	290	620	1027	3/8"
250	10	70	119	198	652	290	620	1416	1/2"
300	6	70	119	234	752	290	620	1525	1/2"

Table. 8

GEAR BOX

This is recommendable for DN's greater than 600.

The definition variables are as follows:

B = Max. width of the valve (without drive).

P = Max. height of the valve (without drive).

OPTIONS:

- Chain handwheel.
- Locking devices.
- Extensions: stand, pipe, plates, etc.
- Non-rising stem.

ACTUATOR:

- Stem
- Yoke
- Cone-shaped gear box
- Handwheel
- Standard ratio = 4 to 1.

AVAILABLE:

- DN50 to DN600

* Other ND on request.

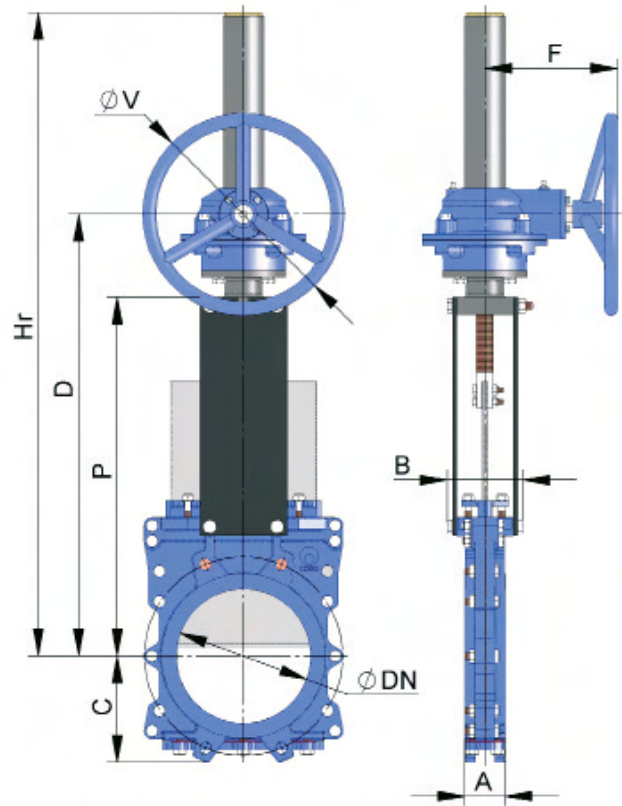

Fig. 20

DN	ΔP bar	A	B	C	P	D	F	ØV	Hr
50	10	40	92	63	241	366	198	300	540
65	10	40	92	70	268	392	198	300	566
80	10	50	92	92	294	418	198	300	592
100	10	50	92	105	334	458	198	300	632
125	10	50	102	120	367	491	198	300	665
150	10	60	102	130	419	543	198	300	717
200	10	60	119	160	525	648	198	300	942
250	10	70	119	198	626	749	198	300	1043
300	6	70	119	234	726	850	198	300	1194
350	6	96	290	256	797	891	218	450	1335
400	6	100	290	292	903	997	218	450	1441
450	5	106	290	308	989	1083	218	450	1677
500	4	110	290	340	1101	1195	218	450	1789
600	4	110	290	400	1307	1401	218	450	2045

Table. 9

DOUBLE-ACTING PNEUMATIC CYLINDER

B = Max. width of the valve (without drive).

The air supply pressure to the pneumatic cylinder is a minimum of 6 bar and a maximum of 10 bar, the air must be dry and lubricated.

10 bar is the maximum admissible air pressure. For air pressures below 6 bar please consult to **CMO Valves**.

For ND50 to ND200 valves, the cylinder's jacket and covers are made of aluminium, the rod of AISI304, the piston of rubber-coated steel and the O-ring seals are made of nitrile.

For valves larger than ND200 the covers are made of nodular cast iron or carbon steel.

On request, we can also supply the actuator made entirely of stainless steel, especially for installation in corrosive atmospheres.

AVAILABLE:

- Standard DN50 to DN300

* Other ND on request..

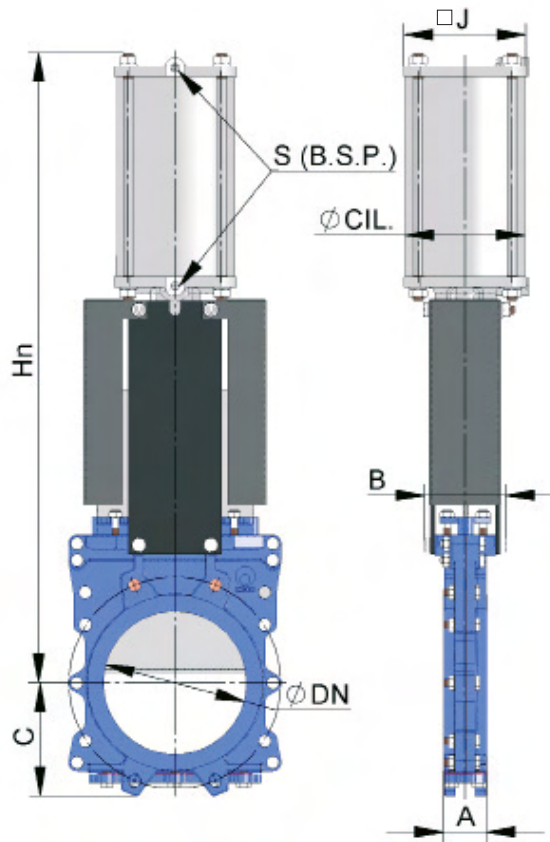

Fig. 21

DN	ΔP bar	A	B	C	ØCIL	ØVAST	J	S (B.S.P.)	Hn
50	10	40	92	63	80	20	96	1/4"	415
65	10	40	92	70	80	20	96	1/4"	455
80	10	50	92	92	80	20	96	1/4"	498
100	10	50	92	105	100	20	115	1/4"	565
125	10	50	102	120	125	25	138	1/4"	636
150	10	60	102	130	125	25	138	1/4"	717
200	10	60	119	160	160	30	175	1/4"	874
250	10	70	119	198	200	30	218	3/8"	1036
300	6	70	119	234	200	30	218	3/8"	1182
350	6	96	290	256	250	40	270	3/8"	1380
400	6	100	290	292	250	40	270	3/8"	1530
450	5	106	290	308	300	45	382	1/2"	1677
500	4	110	290	340	300	45	382	1/2"	1839
600	4	110	290	400	300	45	382	1/2"	2146

Table. 10

SINGLE-ACTING PNEUMATIC CYLINDER

The definition variables are as follows:

B = Max. width of the valve (without actuator)

The air supply pressure to the pneumatic cylinder is a minimum of 6 bar and a maximum of 10 bar, the air must be dry and lubricated.

10 bar is the maximum admissible air pressure. For air pressures below 6 bar please consult to **CMO Valves**.

Available for opening or closing in case of failure (spring opening or closing).

The jacket is made of aluminium, the covers of nodular cast iron or carbon steel, the rod of AISI304, the piston of rubber-coated steel, the O-ring seals of nitrile and the spring is made of steel.

The actuator design is spring activated for valves with diameters up to ND300. For larger diameters the actuator contains a double-acting cylinder and an air tank which stores the volume of air necessary to perform the last movement in the event of a fault.

AVAILABLE

- Standar DN50 to DN300

* Other ND on request.

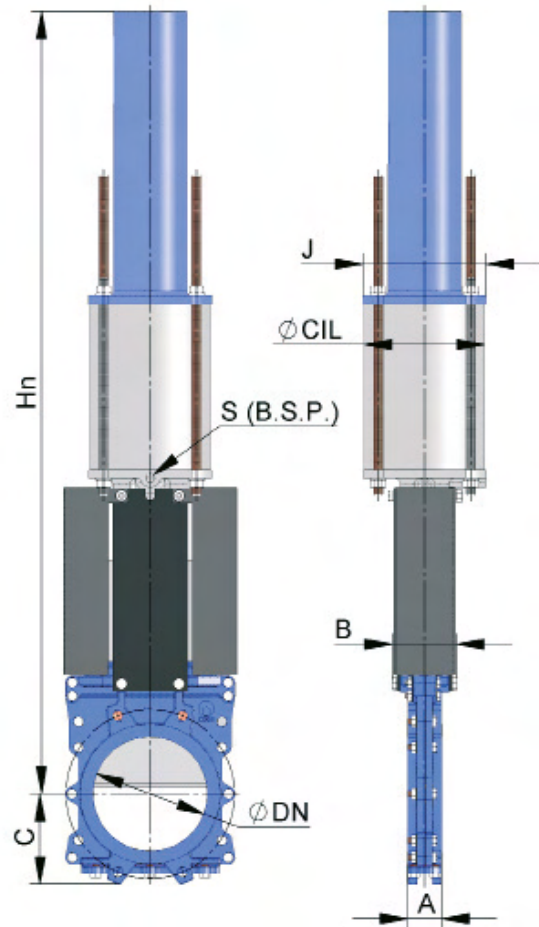

Fig. 22

DN	ΔP bar	A	B	C	Ø CIL	Ø VAST.	J	S (B.S.P.)	Hn
50	10	40	92	63	125	25	138	1/4"	781
65	10	40	92	70	125	25	138	1/4"	806
80	10	50	92	92	125	25	138	1/4"	833
100	10	50	92	105	125	25	138	1/4"	873
125	10	50	102	120	160	30	175	1/4"	909
150	10	60	102	130	160	30	175	1/4"	960
200	10	60	119	160	200	30	218	3/8"	1355
250	10	70	119	198	250	40	270	3/8"	1844
300	6	70	119	234	250	40	270	3/8"	2005

Table. 11

ELECTRIC ACTUATOR

The definition variables are as follows:

B = Max. width of the valve (without drive).

P = Max. height of the valve (without drive).

ACTUATOR AUTOMATIC:

- Electric motor
- Stem
- Yoke

ELECTRIC MOTOR:

- Emergency manual handwheel
- Limit switches
- Torque switches

OPTIONS:

- Different types and brands
- Non-rising stem
- ISO 5210 / DIN 3338 flanges

AVAILABLE

- Standar DN50 to DN600
- From DN500 the motor is assisted with a gear box.

* Other ND on request.

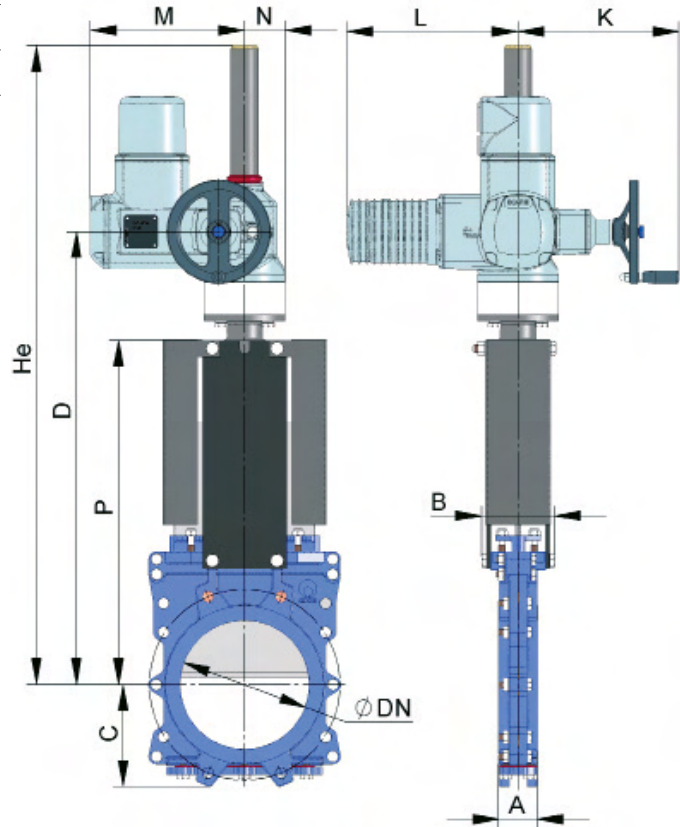

Fig. 23

DN	ΔP bar	A	B	C	D	K	L	M	N	P	He
50	10	40	92	63	400	249	265	238	62	241	595
65	10	40	92	70	426	249	265	238	62	268	622
80	10	50	92	92	452	249	265	238	62	294	647
100	10	50	92	105	492	249	265	238	62	334	687
125	10	50	102	120	525	249	265	238	62	367	720
150	10	60	102	130	577	249	265	238	62	419	772
200	10	60	119	160	685	249	265	238	62	525	990
250	10	70	119	198	785	249	265	238	62	626	1090
300	6	70	119	234	885	249	265	238	62	726	1190
350	6	96	290	256	940	254	283	248	65	797	1305
400	6	100	290	292	1045	254	283	248	65	903	1460
450	5	106	290	308	1175	336	389	286	91	989	1755
500	4	110	290	340	1290	336	389	286	91	1101	1870
600	4	110	290	400	1495	336	389	286	91	1307	2045

Table. 12

HYDRAULIC ACTUATOR

The definition variables are as follows:

B = Max. width of the valve (without actuator)

THE HYDRAULIC ACTUATOR INCLUDES:

- Hydraulic cylinder
- Yoke

Different types and brands available according to customer's requirements.

AVAILABLE:

- Estandard DN50 to DN600.

* Other ND on request.

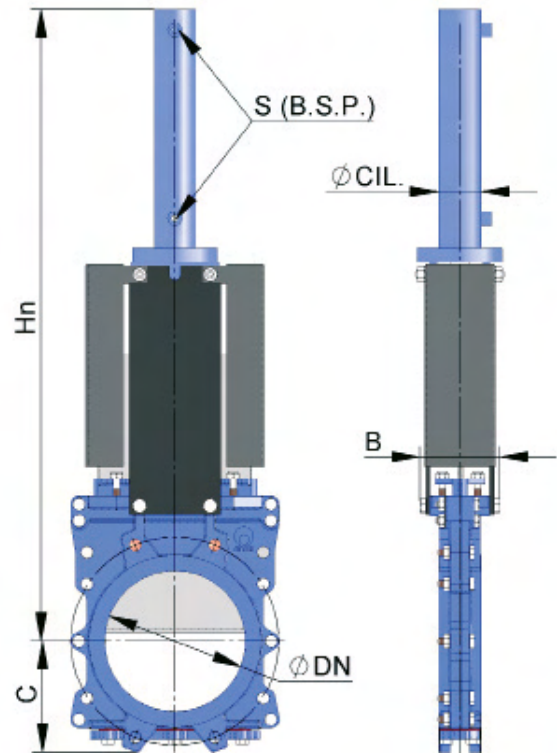

Fig. 24

DN	ΔP bar	A	B	C	Hn	Ø CIL	S (B.S.P.)	OIL CAP. (dm ³)	Ø VAST
50	10	40	92	63	460	25	3/8"	0.03	18
65	10	40	92	70	500	25	3/8"	0.03	18
80	10	50	92	92	560	25	3/8"	0.04	18
100	10	50	92	105	620	32	3/8"	0.09	22
125	10	50	102	120	683	32	3/8"	0.11	22
150	10	60	102	130	755	40	3/8"	0.20	28
200	10	60	119	160	926	50	3/8"	0.42	28
250	10	70	119	198	1077	50	3/8"	0.52	28
300	6	70	119	234	1245	50	3/8"	0.62	28
350	6	96	290	256	1376	50	3/8"	0.73	28
400	6	100	290	292	1535	63	3/8"	1.31	36
450	5	106	290	308	1710	63	3/8"	1.47	36
500	4	110	290	340	1870	63	3/8"	1.62	36
600	4	110	290	400	2175	80	3/8"	3.12	45

Table. 13

FLANGE DIMENSIONS

EN 1092-2 PN10

DN	●	○	M (Metrics)	P	ØK
50	4	0	M 16	8	125
65	4	0	M 16	8	145
80	8	0	M 16	9	160
100	8	0	M 16	9	180
125	8	0	M 16	9	210
150	8	0	M 20	10	240
200	8	0	M 20	10	295
250	8	4	M 20	12	350
300	8	4	M 20	12	400
350	12	4	M 20	21	460
400	12	4	M 24	21	515
450	16	4	M 24	22	565
500	16	4	M 24	22	620
600	16	4	M 27	22	725

Table. 14

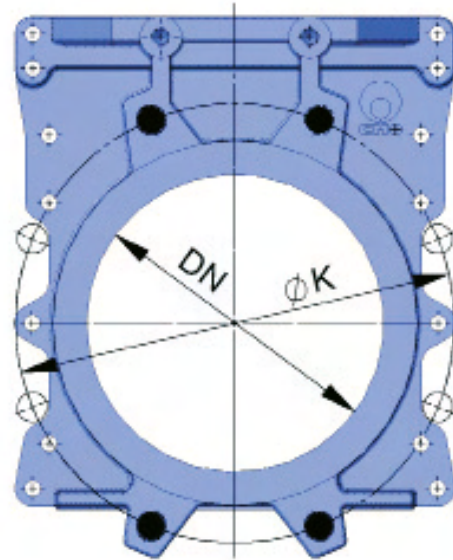

Fig. 25

- TAPPED HOLES
- THROUGH HOLE

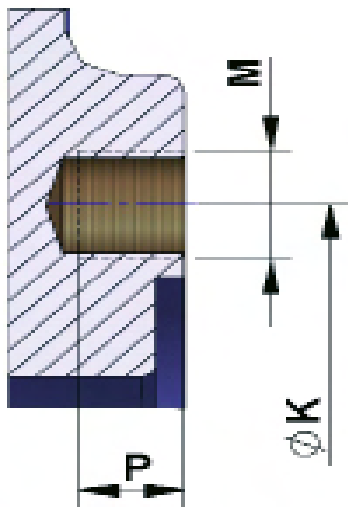

Fig. 26

ANSI B16, Class 150

DN	●	○	M (UNC)	P	ØK
2"	4	0	5/8"	8	120,6
2 1/2"	4	0	5/8"	8	139,7
3"	8	0	5/8"	9	152,4
4"	8	0	5/8"	9	190,5
5"	8	0	3/4"	9	215,9
6"	8	0	3/4"	10	241,3
8"	8	0	3/4"	10	298,4
10"	8	4	7/8"	12	361,9
12"	8	4	7/8"	12	431,8
14"	8	4	1"	21	476,2
16"	12	4	1"	21	539,7
18"	16	4	1 1/8"	22	577,8
20"	16	4	1 1/8"	22	635
24"	16	4	1 1/4"	22	749,3

Table. 15

ARNETT

ENGINEERED SOLUTIONS



ARNETT ENGINEERED SOLUTIONS
61 INNOVATION DRIVE, BAMBERG, SC 29003

(844) 785-7585 | SALES@ARNETT.COM

WWW.ARNETT.COM