



## Series X Knife Gate Valve

## Series X Bidirectional Knife Gate Valve

- Valve suitable for use as end-of-line.
- Monobloc cast iron body.
- Stainless steel through-conduit gate. Two rubber or urethane sleeves.
- Provides high flow rates with low pressure drops.
- Various seat materials available.
- Face-to-face distance in accordance with Arnett standards.

### General applications:

This knife gate valve is suitable for working in the mining industry, in loaded fluid transport lines such as water with stones, sludge, etc, and, in general, for abrasive fluids in the chemical industry and waste water. Designed for the following applications:

- Mining
- Power
- Steel
- Coal
- Chemical
- Alumina
- Phosphate
- Oil Sands
- Bio Fuels
- Sand & Gravel (Aggregate)



**Sizes:** DN50 to DN1500 (larger sizes to order).

**Working ( $\Delta P$ ):**

	<b>Maximum PN</b>
DN50 to DN600	10 kg/cm <sup>2</sup>
DN700 to DN1400	6 kg/cm <sup>2</sup>
DN1500	2 Kg/cm <sup>2</sup>

*The pressures indicated in the table can be used in either of the valve's two directions.*

**Flange borehole:** DIN PN10 & ANSI B16.5 (150 LB)

**Other Common Flanges:**

DIN PN 16 • JIS Standard | DIN PN 6 • Australian Standard | DIN PN 25 • British Standard

## Directives:

- Machinery Directive: DIR 2006/42/EC (MACHINERY)
- Pressure Equipment Directive: DIR 97/23/EC (PED) ART.3, P.3
- Potential Explosive Atmospheres Directive: DIR 94/9/EC (ATEX) CAT.3 ZONE 2 and 22 GD.

**Quality dossier** - All valves are tested hydrostatically and material and test certificates can be provided.

- Body Shell Test  
Each valve body shall be hydrostatically pressure tested at 1.5 times the rated working pressure with no visible leakage. (Leakage through the packing, gate, seat, and temporary flange gaskets or seals shall not be cause for rejection).
- Seat Test (Leakage)  
The hydrostatic seat leakage test shall be performed with the gate closed. The maximum allowable leakage shall be zero at the full rated working pressure.
- Functional Test  
Each valve shall be cycled one complete cycle, from full closed to full open, and from full open to closed to confirm proper operation of valve and accessories (if applicable).
- Gate Test  
Valve is tested with the gate closed at the rated pressure. This ensures gate material integrity.

## Testing Standards

- Manufacturers Standardization Society  
MSS SP-81 applies to bonnetless metal seated knife gate valves, 2" to 24" size, 150 psi CWP. Sizes above 24" are not covered under this standard. Additionally, resilient seated knife gate valves and slide knife gate valves are also not covered under MSS SP-81. These products are subject to the individual manufacturer's internal testing and design standard.
- American Water Works Association  
AWWA C520 standard describes bonneted, bonnetless and one- and two-piece fabricated stainless-steel and cast ductile-iron body knife gate valves with resilient or metal seats, including tapping knife gate valves, for use in water, wastewater, and reclaimed water systems with pH range from 6 to 12 and a temperature range from 33°F to 125°F (0.6°C to 52°C). The minimum design pressure shall be 150 psig (1,034 kPa) for nominal sizes 2 in. to 24 in. (50 mm-600 mm), and the minimum design pressure for nominal sizes 30 in. to 96 in. minimum (750 mm-2,400 mm) shall be 25 psig (172 kPa), 75 psig (517 kPa), and 150 psig (1,034 kPa).

## Advantages of our Series X Valve

- Field replaceable thick urethane/elastomer one piece sleeves are easily replaced without disassembling the valve
- Full port flow reduces pressure drop and turbulence, thus minimizing wear
- 100% bubble-tight shut off
- Optional open bottom allows for the purging of large solids, and solids in high concentration
- Yoke design allows fitting for all designed actuators
- No seat cavities where solids can collect and cause gate interference
- May be used in wet or dry applications
- Body housing drilled and tapped to match ASME B16.5 / 150 flanges.
- This knife-gate valve's main characteristic is that it provides a full continuous flow. This means that in open position it produces no cavities and there are no turbulences in the fluid.
- The Model X valve's body is composed of one single "monoblock" piece.
- The stem protection hood is independent from the handwheel securing nut, this means the hood can be disassembled without the need to release the handwheel. This advantage allows regular maintenance operations to be performed, such as lubricating the stem, etc.
- The stem on the Arnett valve is made of 18/8 stainless steel. This is another added advantage, as some manufacturers produce it with 13% chrome and it gets rusty very quickly.
- The handwheel is made of GJS-500 nodular cast iron. Some manufacturers produce them in normal cast iron which can lead to breakages in the event of very high operating torque or knocks.
- The yoke is has a compact design with the bronze actuator nut protected in a sealed and lubricated box. This makes it possible to move the valve with a key, even without the handwheel (in other manufacturers' products this is not possible).
- The pneumatic actuator's upper and lower covers are made of GJS-500 nodular cast iron, making them highly shock resistant. This characteristic is essential in pneumatic actuators.



Standard Components List		
Component	Cast Iron Version	Stainless Steel Version
1. Body	GJS-500	CF8M
2. Gate	AISI304	AISI316
3. Packing Gland	Steel	AISI316
4. Packing Seal	Natural Rubber	
5. Gasket	Lubricated Gasket	AISI316
6. Bottom Cover	Steel	AISI316
7. Sleeve	Natural Rubber	
8. Retainer Sleeve	Natural Rubber	
9. Support Plates	Steel	Steel
10. Stem	AISI303	AISI303
11. Yoke	GJS-500	GJS-500
12. Stem Nut	Bronze	Bronze
13. Handwheel	GJS-500	GJS-500
14. Stopper Nut	Steel	Steel
15. Hood nut	5.6 Zinc	5.6 Zinc
16. Hood	Steel	Steel
17. Protection Cap	Plastic	Plastic

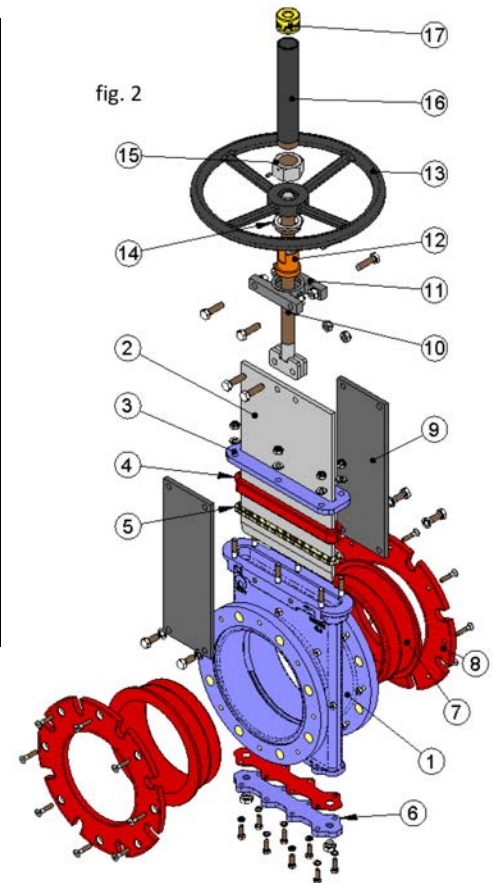

## Design Characteristics

### 1. BODY

Reinforced monobloc cast iron body. The body provides a full continuous flow. This means that in open position it produces no cavities and, therefore, there is no turbulence in the fluid and the load loss is minimal. For diameters greater than DN600 the body is machine-welded with the necessary reinforcements to withstand the maximum working pressure. Designed with full passage to provide large flows with small losses of load. The body's internal design prevents any build-up of solids in the seal area. The standard manufacturing materials are GJS-500 and CF8M stainless steel. Other materials such as A216WCB carbon steel and stainless steel alloys (AISI316Ti, Duplex, 254SMO, Uranus B6, Ni-Resist, Ductile Ni-Resist, etc.) are available to order. As standard, iron or carbon steel valves are painted with an anti-corrosive protection of 80 microns of EPOXY (colour RAL 5015). Other types of anti-corrosive protections are available to order.

### 2. THROUGH-CONDUIT GATE

The standard manufacturing materials are AISI316 stainless steel in valves with GJS-500 body, and AISI316 stainless steel in valves with CF8M body. Other materials or combinations can be supplied to order. The through-conduit gate is polished on both sides to provide a smooth contact surface with the resilient seal. At the same time, the sharp edges on the gate are rounded to prevent the seal being cut. There are different degrees of polishing, anti-abrasion treatments and various options to adapt the valves to the customer's requirements.

### 3. SEAT(sealtight)

The Series X valve seat comprises two rubber sleeves located symmetrically on each side of the body, both secured with sleeve retainers. Both the sleeve retainers and the sleeves are made of natural rubber with a metal core which helps to keep their shape and also prevent deformations. Whilst the valve is in open position, the sleeves' elasticity ensures they are joined together permanently, preventing the accumulation of solids between the two parts of the body. The GA valve is designed for abrasive fluids, and, therefore, the sleeves protect the entire surface of the body which would be exposed to the abrasive flow. For easier maintenance, the sleeves can be replaced from outside the valve. It is a symmetrical two-piece seat; see the drawing of a seat (fig 3).

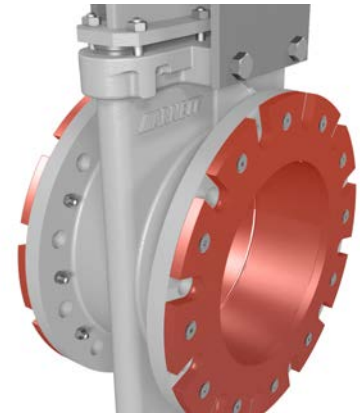

#### Sealtight materials

**ULTRATHANE**– Our Ultrathane F70 is the flagship material for the Series X. This is the standard single piece urethane seat fitted on Series H model valves. The Arnett Ultrathane material can be customized to fit your application demands. It can be used in multiple applications at temperatures no higher than 70°C with abrasive products and it provides the valve with 100% watertight integrity.

**NATURAL RUBBER** - This is the standard hermetic seal fitted in Arnett Series X model valves. It can be used in multiple applications at temperatures below 90°C with abrasive products, and it provides the valve with 100% sealtight integrity. Application: fluids in general.

**EPDM** - Recommended for temperatures below 90°C\*. Provides the valve with 100% sealtight integrity. Application: water and acids.

**NITRILE** - Used in fluids containing fats or oils at temperatures no higher than 90°C\*. Provides the valve with 100% sealtight integrity.

**VITON** - Suitable for corrosive applications and high temperatures of up to 190°C and peaks of 210°C. Provides the valve with 100% sealtight integrity.

Seat/Seals		
Material	Max. Temp (C)	Applications
Ultrathane	70°C / 158°F	General / Fine, abrasive slurry
Natural Rubber	90°C / 194°F	General
EPDM (E)	90°C / 194°F	Non-mineral oils, water and acids
Nitrile (N)	90°C / 194°F	Hydrocarbons, oils and greases
Viton (V)	200°C / 392°F	Hydrocarbons, oils and solvents

Note: More details and other materials available to order.  
\*EPDM and Nitrile: Possible up to Max Temp of 120 C on request

#### 4. **PACKING**

Arnett's standard gasket is composed of a specially designed EPDM O-ring which provides sealtight integrity between the body and the gate, preventing any type of leakage to the atmosphere. It also has a lubricated gasket strip to help the valve's operation during the opening and closing functions. It is located in an easily accessible place and can be replaced without dismantling the valve from the pipeline. Scraper in the packing is also available, which functions to clean the gate during the opening movement and prevent possible damage to the packing.

#### 5. **STEM**

The Arnett valve stem is made from stainless steel 18/8. This characteristic makes it highly resistant and provides excellent properties against corrosion. The valve design can be rising stem or non-rising stem. When a rising stem is required for the valve, a stem hood is supplied to protect the stem from contact with dust and dirt, besides keeping it lubricated.

#### 6. **PACKING GLAND**

The packing gland allows uniform force and pressure to be applied to the gasket to ensure sealtight integrity. As standard, valves with steel body include steel packing glands, whilst valves with stainless steel body have stainless steel packing glands.

#### 7. **ACTUATORS**

It is possible to supply all types of actuators, with the advantage that the Arnett design is completely interchangeable. This design means customers can change the actuator themselves without any additional assembly accessories. A design characteristic of Arnett valves is that all actuators are interchangeable.

Manual	Automatic
Handwheel with rising stem	Electric actuator
Handwheel with non-rising stem	Pneumatic actuator
Chainwheel	Hydraulic cylinder
Lever	
Gearbox	
Others (square stem, etc.)	

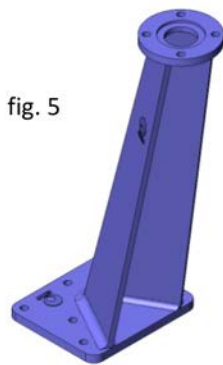
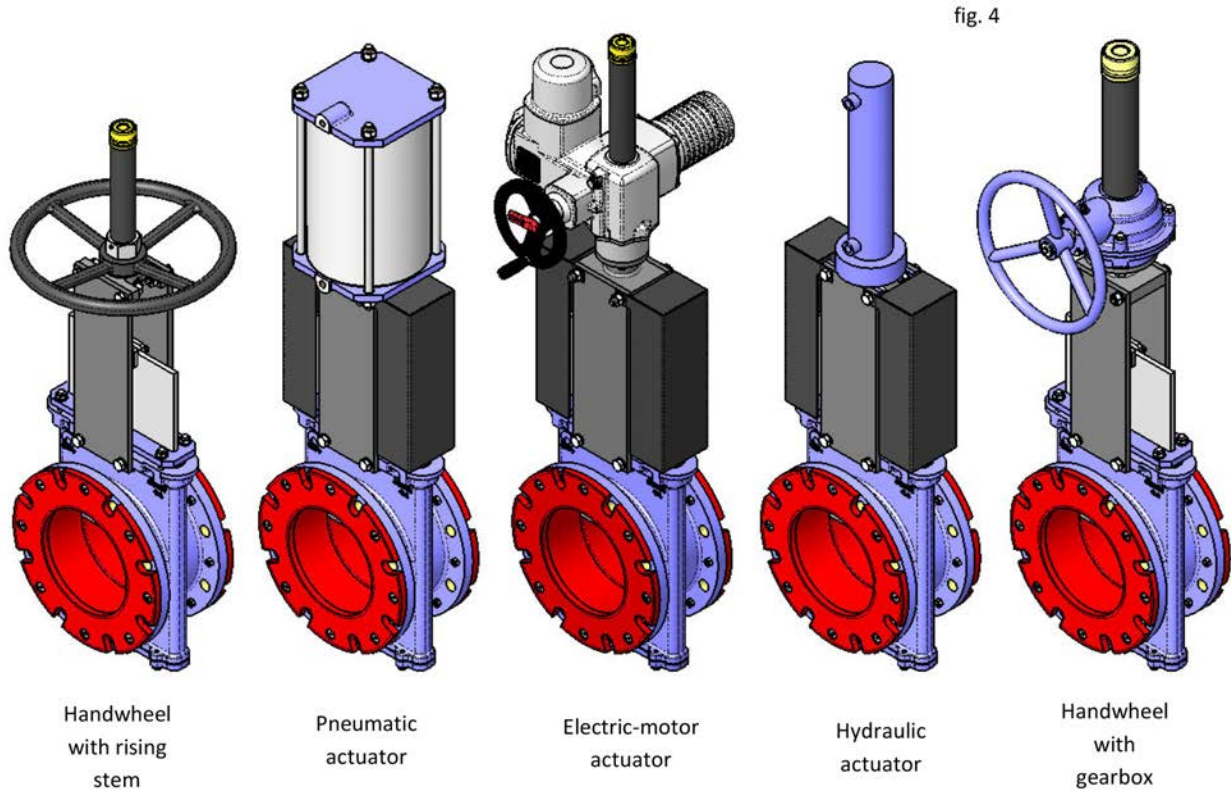

**Wide range of accessories available:**

- Mechanical stoppers
- Locking devices
- Emergency manual actuators
- Electrovalves
- Positioners
- Limit switches
- Proximity detectors
- Straight floor stand (fig. 6)
- Leaning floor stand (fig. 5)

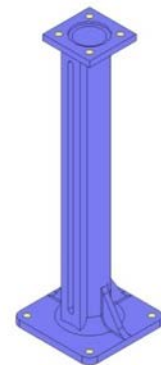

Stem extensions have also been developed, allowing the actuator to be located far away from the valve, to suit all needs. Please check with our technicians beforehand.



## Accessories and Options

Different accessories are available to adapt the valve to specific working conditions such as:

- **PTFE/HVOF Lined Gate:** Chromium carbide lined gate adds additional wear and corrosion resistance, and also ensures the solids slide off and do not stick to the gate.
- **Cased body:** Recommended in applications in which the fluid can harden and solidify inside the valve body. An external casing keeps the body temperature constant, preventing the fluid from solidifying.
- **Flushing holes in the body:** Several holes are drilled in the body to flush air, steam or other fluids out with the aim of cleaning the valve seat before sealing.
- **Electrovalves (fig. 7):** For air distribution to pneumatic actuators.
- **Junction boxes, wiring and pneumatic piping:** Units supplied fully assembled with all the necessary accessories.
- **Mechanical limit switches, inductive sensors and positioners:** Limit switches or sensors are installed to indicate precise valve position, as well as positioners to indicate continuous position (fig. 7).
- **Junction boxes, wiring and pneumatic piping:** Units supplied fully assembled with all the necessary accessories.
- **Mechanical locking device:** Allows the valve to be mechanically locked in a set position for long periods.
- **Stroke limiting mechanical stops:** Allow the stroke to be mechanically adjusted, limiting the valve run.
- **Emergency manual actuator (hand wheel/gearbox)(fig. 7):** Allows manual operation of the valve in the event of power or air failure.
- **Interchangeable actuators:** All actuators are easily interchangeable.
- **Actuator or yoke support:** Made of EPOXY-coated steel (or stainless steel to order), its robust design gives it great rigidity in order to withstand the most adverse operation conditions.
- **Epoxy coating:** All cast iron and carbon steel bodies and components in Arnett valves are EPOXY coated, giving the valves great resistance to corrosion and an excellent finish.
- **Through-conduit gate safety guard:** Arnett automatic valves are fitted with metal guards in the gate run in order to prevent objects from being accidentally caught or dragged along.

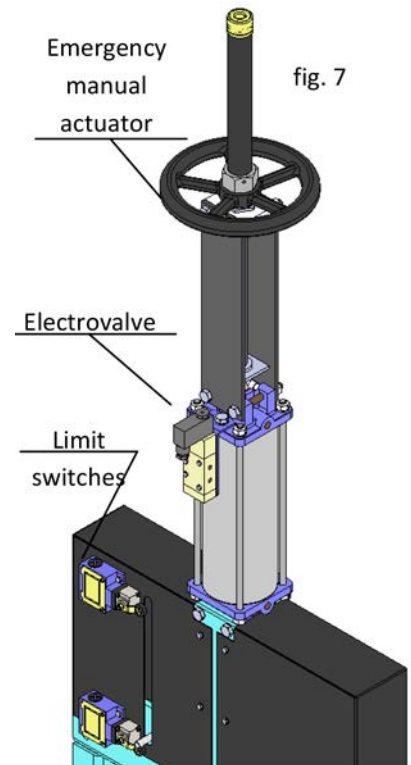

## Sales & Engineering

401 Westpark Court, Suite 200  
Peachtree City, GA 30269

## Corporate Office

132 Sandisfield Dr  
Sharpsburg, GA 30277

## Distribution, Manufacturing & Repair

### **Southeast Office:**

116 Bethea Road, Suite 414  
Fayetteville, GA 30214

### **Southwest Office:**

1881 East University Drive  
Phoenix, Arizona 85034

 [arnett.com](http://arnett.com) /  [info@arnett.com](mailto:info@arnett.com)

